

Multifunctional damper actuator for adjusting air dampers in ventilation and air conditioning systems in buildings

- Air damper size up to approx. 2 m²
- Torque 10 Nm
- Nominal voltage AC/DC 24 V
- Control: Modulating DC 0 ... 10 V or variable
- Position feedback DC 2 ... 10 V or variable



Technical data

Electrical data

Nominal voltage	AC 24 V, 50/60 Hz / DC 24 V
Power supply range	AC 19.2 ... 28.8 V / DC 21.6 ... 28.8 V
Power consumption In operation	3.5 W at nominal torque
At rest	1.25 W
For wire sizing	5.5 VA
Connection	Cable 1 m, 4 x 0.75 mm ²

Functional data	Factory settings	Variable	Settings
Torque (nominal torque)	Min. 10 Nm at nominal voltage	25%, 50%, 75% reduced
Control Control signal Y Working range	DC 0 ... 10 V, input impedance 100 kΩ DC 2 ... 10 V	Open-close, 3-point (AC only) Start point DC 0.5 ... 30 V End point DC 2.5 ... 32 V
Position feedback (measuring voltage U)	DC 2 ... 10 V, max. 0.5 mA	Start point DC 0.5 ... 8 V End point DC 2.5 ... 10 V
Uni-rotation	±5%		
Direction of rotation	Can be selected with 0 / 1		
Direction of motion at Y = 0 V	In switch position 0 ↶ or 1 ↷	Electronically reversible
Manual override	Disengaging the gearing latch by means of a pushbutton, self-resetting		
Angle of rotation	Max. 95° ↶, can be limited at both ends with mechanical adjustable end stops		
Running time	150 s	43 ... 173 s
Automatic adjustment of running time, operating range and measuring signal U to match the mechanical angle of rotation	Manual triggering of this adaption by pressing the button «Adaption» or with the PC-Tool	Automatic adaption whenever the supply voltage is switched on, or manual triggering
Override control	MAX (maximum position) = 100% MIN (minimum position) = 0% ZS (intermediate position, AC only) = 50%	MAX = (MIN + 30° ↶) ... 100% MIN = 0% ... (MAX - 30° ↶) ZS = MIN ... MAX
Sound power level	Max. 35 dB (A)	With a running 43 s = 45 dB (A) time of 173 s = 35 dB (A)	
Position indication	Mechanical, plug-on		

Safety

Protection class	III Safety extra-low voltage
Degree of protection	IP54 in all mounting positions
EMC	CE according to 89/336/EEC
Mode of operation	Type 1 (to EN 60730-1)
Rated impulse voltage	0.8 kV (to EN 60730-1)
Control pollution degree	3 (in acc. with EN 60730-1)
Ambient temperature range	-30 ... +50°C
Non-operating temperature	-40 ... +80°C
Ambient humidity range	95% r.H., non-condensating (to EN 60730-1)
Maintenance	Maintenance-free

Technical data *(Continued)*

Dimensions/weight

Dimensions	See «Dimensions» on page 5
Weight	Approx. 710 g

Safety notes



- The damper actuator is not allowed to be used outside the specified field of application, especially in aircraft or in any other airborne means of transport.
- It may only be installed by suitably trained personnel. All applicable legal or institutional installation regulations must be complied with.
- The device may only be opened at the manufacturer's site. It does not contain any parts that can be replaced or repaired by the user.
- The cable is not allowed to be removed from the unit.
- When calculating the torque required, the specifications supplied by the damper manufacturers concerning the cross section, design and installation site, and the air flow conditions must be observed.
- The device contains electrical and electronic components and is not allowed to be disposed of as household refuse. All locally valid regulations and requirements must be observed.

Product features

Mode of operation	The actuator is controlled with a standard modulating signal of DC 0 ... 10 V and travels to the position defined by the control signal. Measuring voltage U serves for the electrical display of the damper position 0 ... 100% and as slave control signal for other actuators.
Parameterisable actuators	The factory settings cover the most common applications. Input and output signals and other parameters can be altered with the MFT-H parameterising device or the BELIMO Service Tool, MFT-P.
Simple direct mounting	Simple direct mounting on the damper spindle with a universal spindle clamp, supplied with an anti-rotation strap to prevent the actuator from rotating.
Manual override	Manual operation with self-resetting pushbutton possible (the gear is disengaged for as long as the button is pressed).
Adjustable angle of rotation	Adjustable angle of rotation with mechanical end stops.
High functional reliability	The actuator is overload-proof, requires no limit switches and automatically stops when the end stop is reached.
Home position	When the supply voltage is switched on for the first time, i.e. at commissioning or after pressing the «gear disengagement» switch, the actuator travels to the home position.

Pos. direction of rotation switch	Home position
 Y = 0	Left stop
Y = 0	Right stop

The actuator then moves into the position defined by the control signal.

Accessories

	Description	Data sheet
Electrical accessories	Auxiliary switch S..A..	T2 - S..A..
	Feedback potentiometer P..A..	T2 - P..A..
	Manual parameterising device MFT-H	T2 - MFT-H
	PC-Tool MFT-P	T2 - MFT-P
	Position sensor SG..24	T2 - SG..24
	Digital position indication ZAD24	T2 - ZAD24
Mechanical accessories	Various accessories (clamps, shaft extensions etc.)	T2 - Z-NM..A..

Electrical installation

Wiring diagram

Note

- Connect via safety isolation transformer.
- Parallel connection of other actuators possible. Note the performance data.

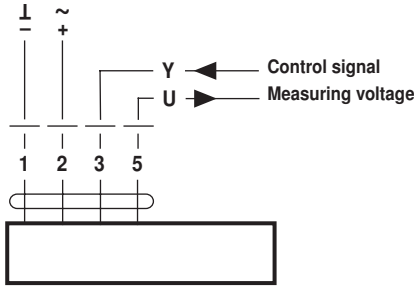

Functions with basic values

Override control with AC 24 V with relay contacts

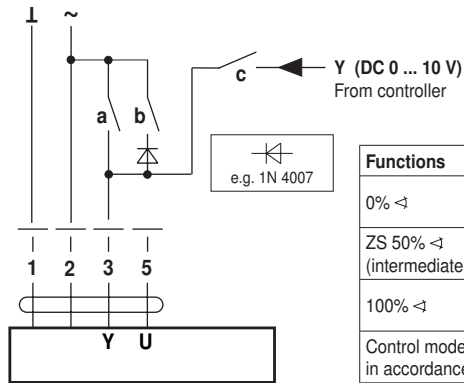

Functions	a	b	c
0% <-	—	—	—
ZS 50% <- (intermediate position)	—	—	—
100% <-	—	—	—
Control mode in accordance with Y	—	—	—

Override control with AC 24 V with rotary control switch

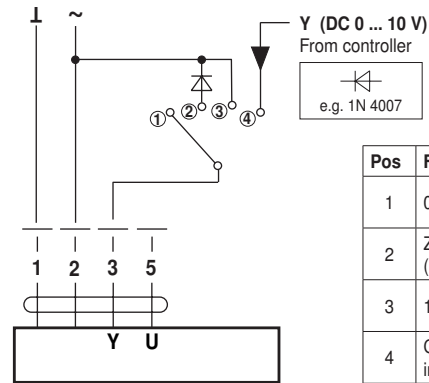

Pos	Functions
1	0% <-
2	ZS 50% <- (intermediate position)
3	100% <-
4	Control mode in accordance with Y

Remote control 0 ... 100 %

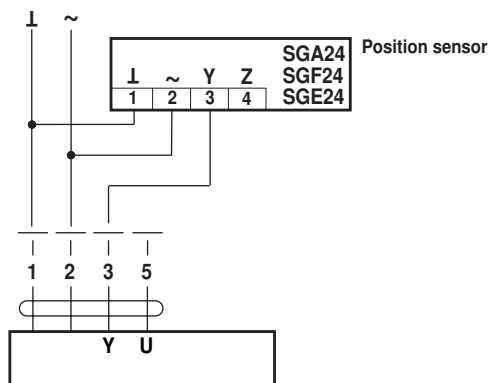

Minimum limit

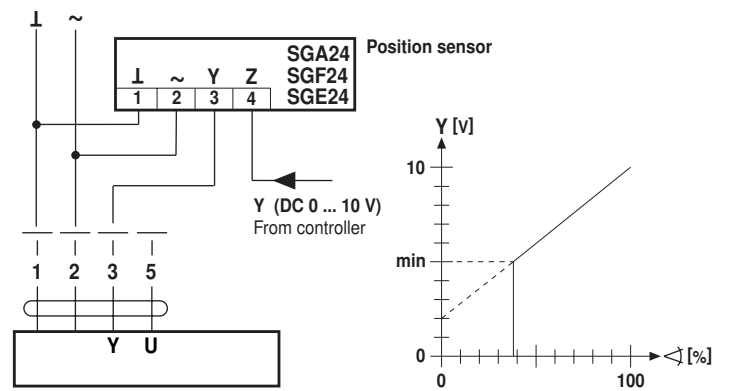

Master/Slave control (position-dependent)

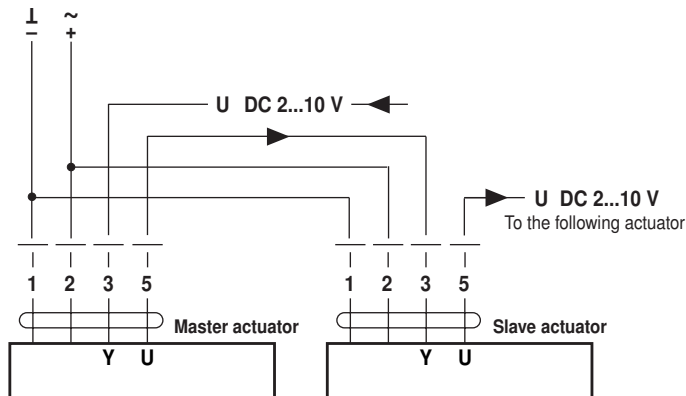

Control with 4 ... 20 mA via external resistance

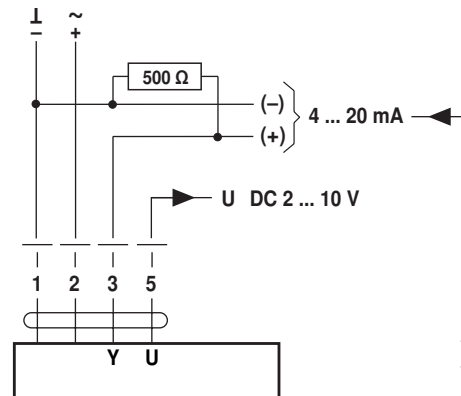

The 500 Ω resistor converts the 4 ... 20 mA current signal to a voltage signal DC 2 ... 10 V

Functions with basic values

(continued)

Position indication

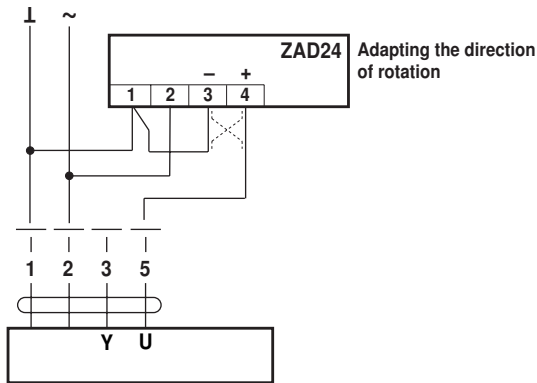

Functional check

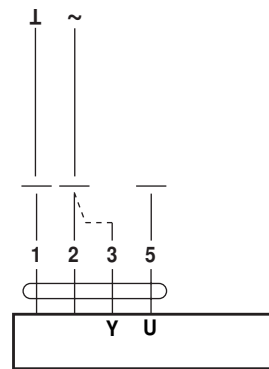

Procedure

- Apply AC 24 V to connection 1 and 2
- Disconnect connection 3:
 - For direction of rotation 0: Actuator turns in the direction of ↺
 - For direction of rotation 1: Actuator turns in the direction of ↻
- Short circuit connections 2 and 3:
 - Actuator runs in the opposite direction

Functions for actuators with specific parameters

Override control and limiting with AC 24 V with relay contacts

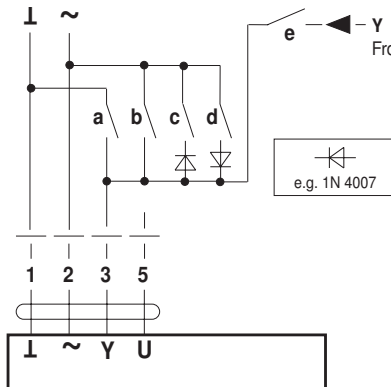

Functions	a	b	c	d	e
CLOSE ¹⁾					
MIN					
ZS (intermediate position)					
MAX					
OPEN					
Control mode in accordance with Y					

Override control and limiting with AC 24 V with rotary switch

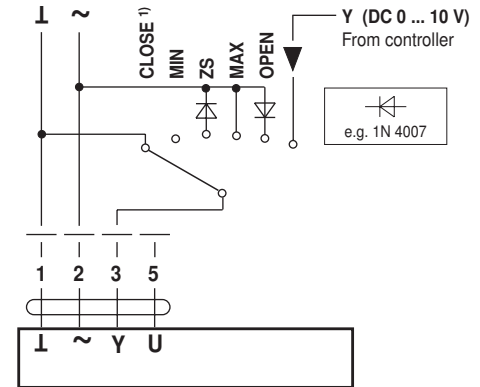

¹⁾ **Caution!** This function is only guaranteed if the start point of the operating range is defined as min. 0.6 V.

3-point control

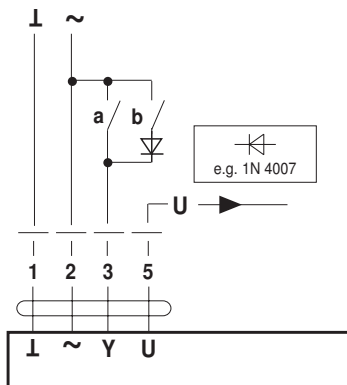

		Direction of rotation switch	
a	b	0	1
		stop	stop

Open/close control

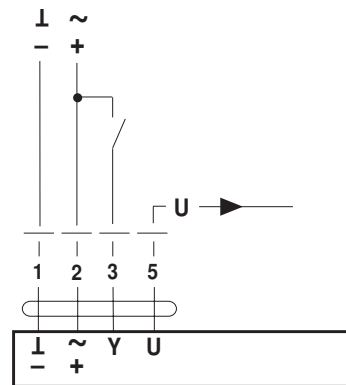

Dimensions [mm]

Dimensional diagrams

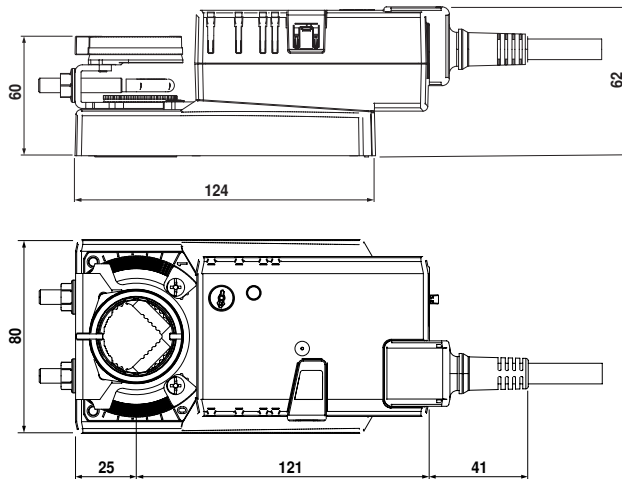

Damper spindle	Length	
Clamp, top	Min. 40	8 ... 26.7
Clamp, bottom *	Min. 20	8 ... 20

* Option (accessories K-NA)

Operating controls and indicators



- 1 Direction of rotation switch**
Switching over: Direction of rotation changes
- 2 Pushbutton and green LED display**
Off: No voltage supply or malfunction
Green on: Operation
Press button: Switches on angle of rotation adaption followed by standard operation
- 3 Pushbutton and yellow LED display**
Off: Standard operation
Yellow on: Adaption or synchronising process active
Press button: No function
- 4 Gear disengagement switch**
Press button: Gear disengaged, motor stops, manual operation possible
Release button: Gear engaged, synchronisation starts, followed by standard operation
- 5 Service plug**
For connecting parameterising and service tools

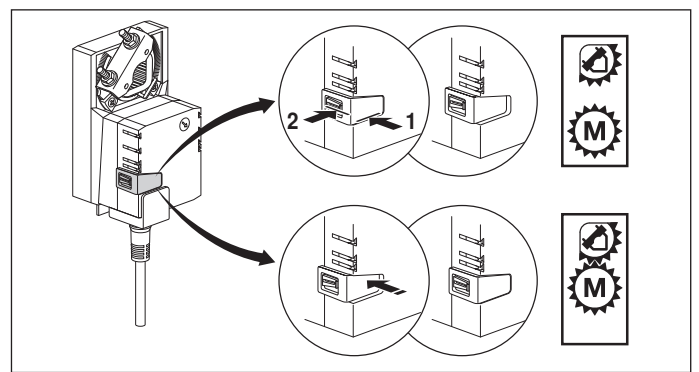
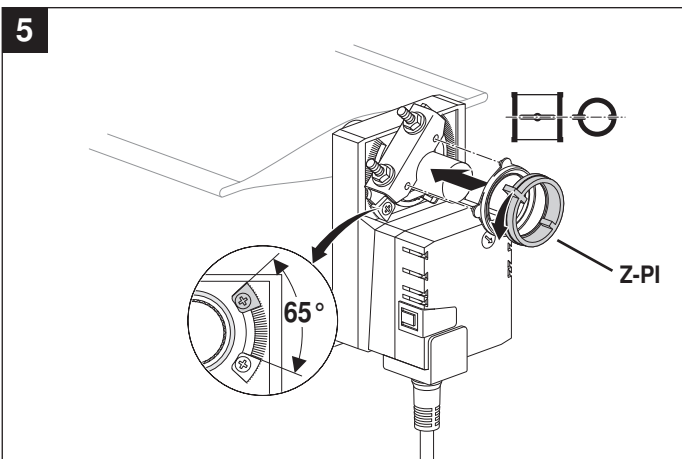
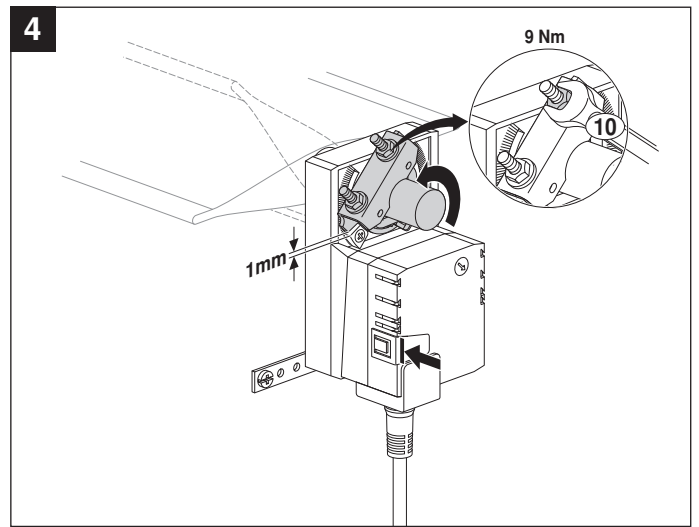
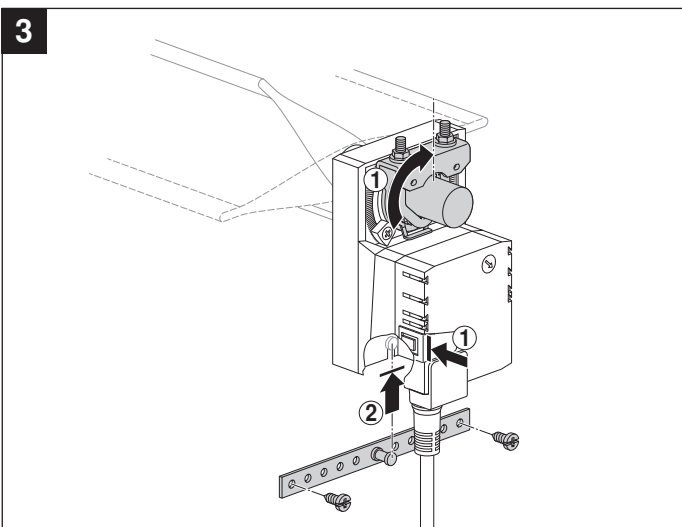
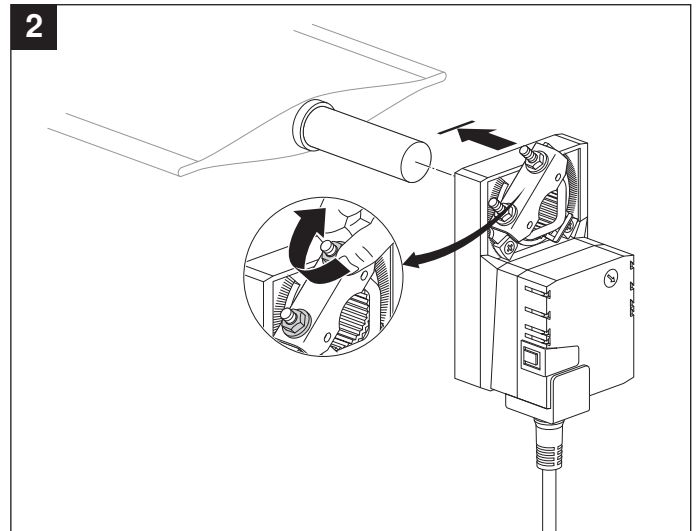
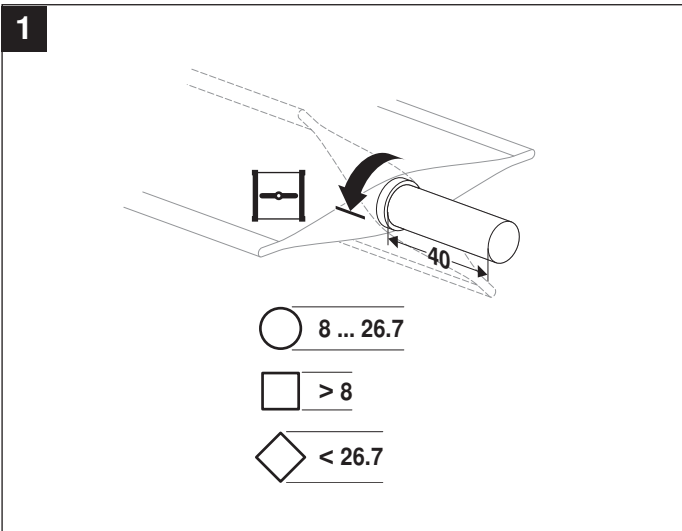

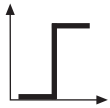
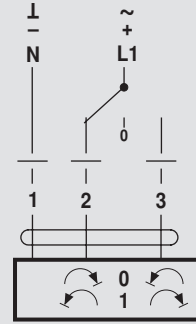
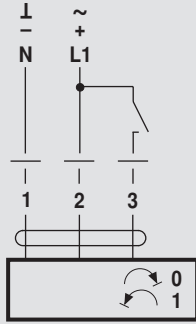

AC 24 V / DC 24 V
DC 48 ... 110 V (NM72A..) ⚠

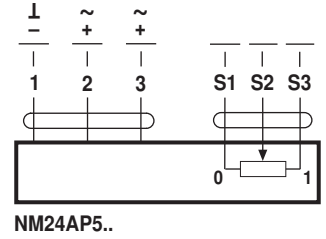
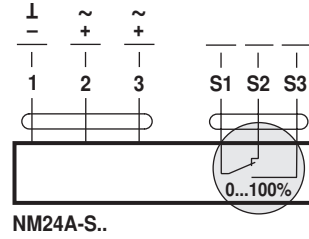
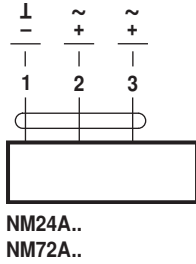

AC 100 ... 240 V ⚠

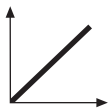
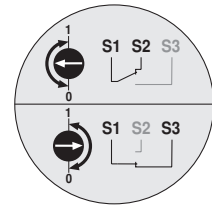
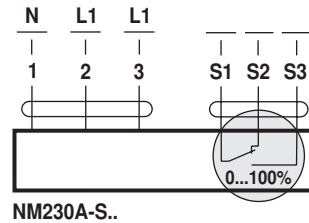
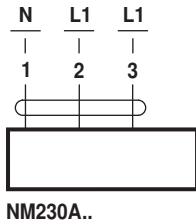

AC 24 V / DC 24 V

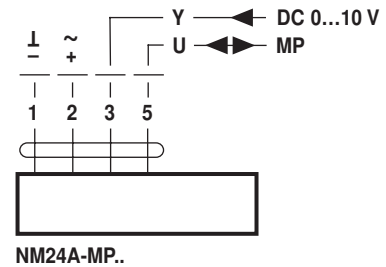
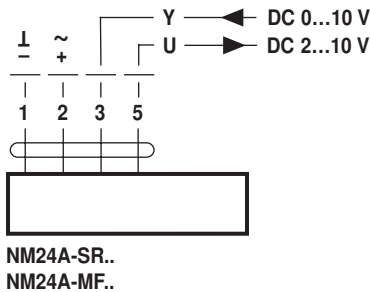

DC 48 ... 110 V (NM72A-SR..) ⚠

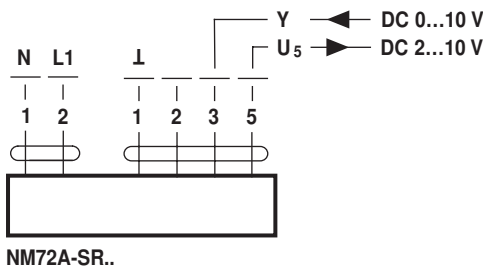

AC 100 ... 240 V ⚠

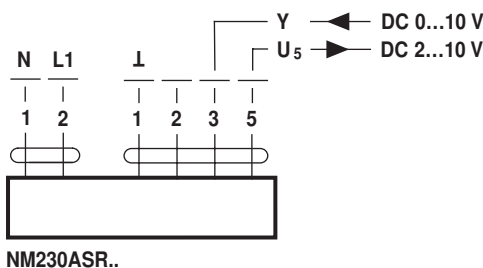

AC 24 V / DC 24 V (NM24A-V / VR..) ⚠

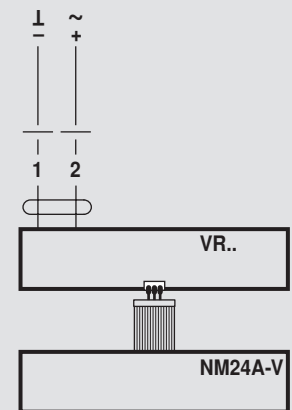

NM230A-V / VR..