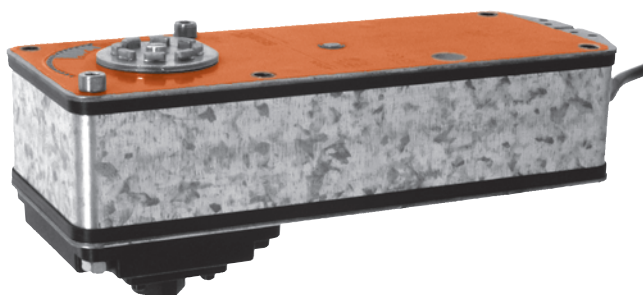

Modulating rotary actuator with emergency control function for 2- and 3-way characterized control valves

- Torque 15 Nm
- Nominal voltage AC/DC 24 V
- Control: modulating DC 0 ... 10 V, position feedback DC 2 ... 10 V
- Auxiliary switch
- ARF24-SR-S: Deenergised NC
ARF24-SR-S-O: Deenergised NO

Technical data

Electrical data	Nominal voltage	AC 24 V, 50/60 Hz DC 24 V	
	Power supply range	AC 19.2 ... 28.8 V DC 21.6 ... 28.8 V	
	Power consumption	Spring return 6 W at nominal torque Holding position 2.5 W For wire sizing 10 VA	
	Auxiliary switch	2 x SPDT, 6 (3) A, AC 250 V II □ Switching points: 10% ↯ fixed, 28 ... 94% ↯ adjustable	
	Connection	Motor Cable 1 m, 2 x 0.75 mm ² Auxiliary switch Cable 1 m, 6 x 0.75 mm ²	
	Parallel connection	Yes (Note the performance data supply!)	
Functional data	Torque (nominal torque)	Motor Min. 15 Nm at nominal voltage Spring return Min. 15 Nm	
	Control	Control signal Y DC 0 ... 10 V, typical input impedance 100 kΩ Working range DC 2 ... 10 V	
	Position feedback (Measuring voltage U)	DC 2 ... 10 V, max. 0.5 mA	
	Direction of rotation	Motor Switch R / L Spring return ARF24-SR-S Deenergised NC, ball valve closed (A – AB = 0%) Spring return ARF24-SR-S-O Deenergised NO, ball valve open (A – AB = 100%)	
	Manual override	With hand crank, can be fixed in any position	
	Angle of rotation	95° ↯	
	Running time	Motor 150 s Spring return ~16 s at -20 ... 50°C / max. 60 s at -30°C	
	Noise level	Motor Max. 45 dB (A) Spring return ~62 dB (A)	
	Service life	Min. 60'000 emergency settings	
	Position indication	Mechanical	
	Safety	Protection class	III Extra low voltage
		Degree of protection	IP54
EMC		CE according to 89/336/EEC	
Mode of operation		Type 1 (to EN 60730-1)	
Rated impulse voltage		0.8 kV (to EN 60730-1)	
Control pollution degree		3 (to EN 60730-1)	
Ambient temperature range		-30 ... +50°C	
Media temperature		+5 ... +100°C (in ball valve)	
Non-operating temperature		-40 ... +80°C	
Ambient humidity range		95% r.H., non-condensating (to EN 60730-1)	
Maintenance	Maintenance-free		
Dimensions / Weight	Dimensions	See «Dimensions» on page 2	
	Weight	Approx. 2.7 kg (without ball valve)	

Safety notes

- The actuator has been designed for use in stationary heating, ventilation and air conditioning systems and is not allowed to be used outside the specified field of application, especially in aircraft or in any other airborne means of transport.
- It may only be installed by suitably trained personnel.
All applicable legal or institutional installation regulations must be complied with.

Safety notes

(Continue)

- The device may only be opened at the manufacturer's site. It does not contain any parts that can be replaced or repaired by the user.
- The device contains electrical and electronic components and is not allowed to be disposed of as household refuse. All locally valid regulations and requirements must be observed.

Product features

Mode of operation	The actuator moves the damper to its normal working position while tensioning the return spring at the same time. If the power supply is interrupted, the energy stored in the spring moves the damper back to its safe position.
Simple direct mounting	Straightforward direct mounting on the ball valve with only one screw. The mounting position in relation to the ball valve can be selected in 90° steps.
Manual override	The ball valve can be manually operated and fixed in any position using a hand crank. Unlocking is manual or automatic by applying the operating voltage.
High functional reliability	The actuator is overload-proof, requires no limit switches and automatically stops when the end stop is reached.
Signalling	The actuator has one adjustable auxiliary switch and one auxiliary switch with a fixed setting. This means angles of rotation of 10% or 28 ... 94% can be signalled.
Combination valve actuators	Refer to the valve documentation for suitable valves, their permitted media temperatures and closing pressures.

Electrical installation

Wiring diagram / Direction of rotation

Note

- Connect via safety isolation transformer.
- Parallel connection of other actuators possible. Note the performance data supply.

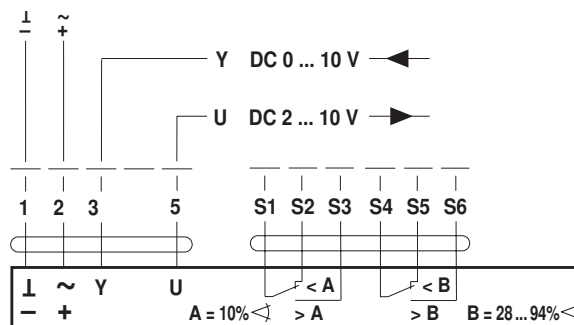

Direction of rotation

ARF24-SR-S-O	ARF24-SR-S	
L	R	
Reversing switch		
R L	L R	
Y = 0	Y = 0	
		A - AB = 0%

Dimensions [mm]

Dimensional diagrams

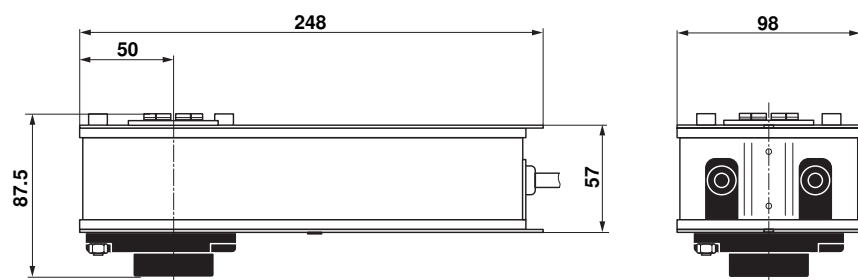

Further documentations

- Complete overview of actuators for water solutions
- Data sheets for ball valves
- Installation instructions for actuators and/or ball valves
- Notes for project planning (hydraulic characteristic curves and circuits, installation regulations, commissioning, maintenance etc.)

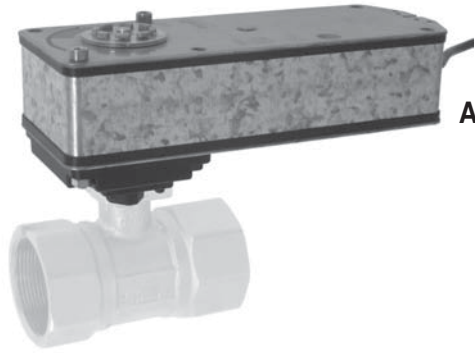

ARF24-SR-S(-0)

70179-00001.A

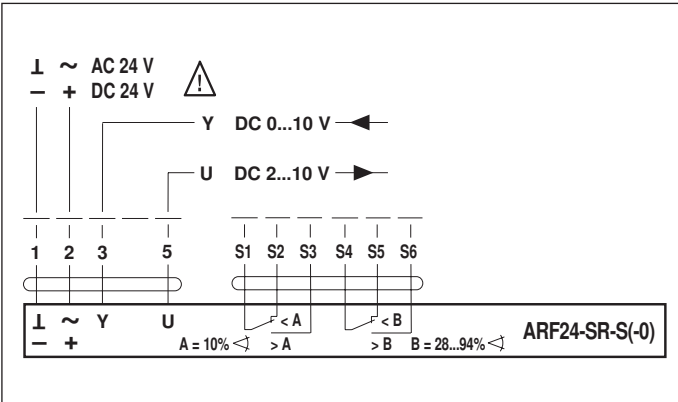
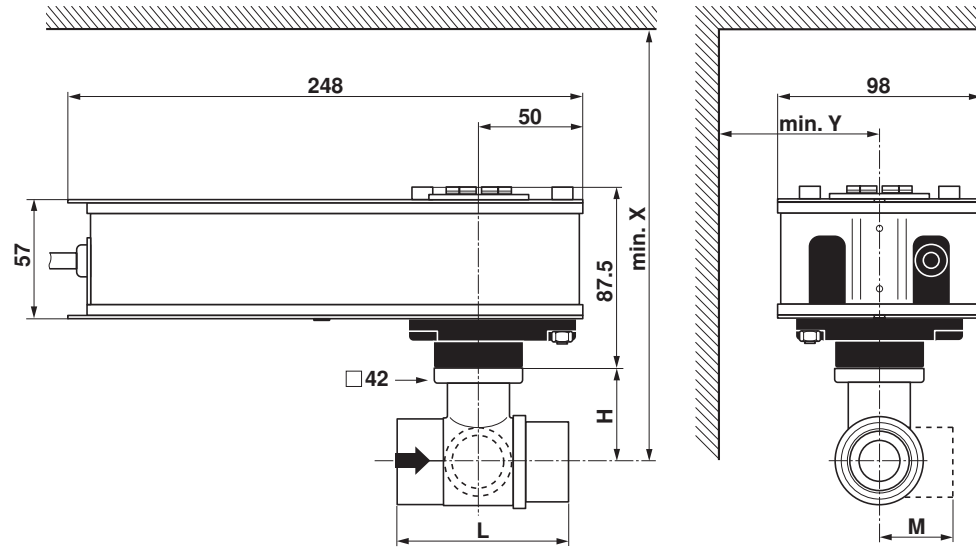

	DN		Rp	G	mm				
	mm	"			L	H	M	X	Y
R2.. / R3..	15	1/2	1/2"		67	45	39	203	90
R4.. / R5..			1"	74	44	38	202	90	
R6..R / R7..R			PN6	101.5	45	73	203	90	
R2.. / R3..	20	3/4	3/4"		78	47.5	41.5	205	90
R4.. / R5..			1 1/4"	85.5	46	42.5	204	90	
R6..R / R7..R			PN6	112	47.5	79	205	90	
R2.. / R3..	25	1	1"		87	47.5	45	205	90
R4.. / R5..			1 1/2"	84.5	46	47.5	204	90	
R6..R / R7..R			PN6	132	47.5	92	205	90	
R2.. / R3..	32	1 1/4	1 1/4"		105	52	55.5	210	90
R4.. / R5..			2	102	50.5	56	208	90	
R6..R / R7..R			PN6	143.5	52	102.5	210	100	
R2.. / R3..	40	1 1/2	1 1/2"		111	52	56	210	90
R4.. / R5..			2 1/4	103	50.5	60.5	208	90	
R6..R / R7..R			PN6	149.5	52	105	210	105	
R2.. / R3..	50	2	1 3/4"		125	58	68	210	90
R4.. / R5..			2 3/4	115.5	56	71.5	214	90	
R6..R / R7..R			PN6	165	58	121	216	110	
R6..R	65	2 1/2			180.5	69		227	120
	80	3			191.5	69		227	135

ARF24-SR-S

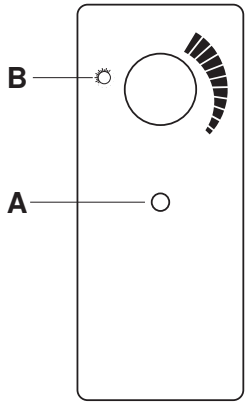

ARF24-SR-S-0

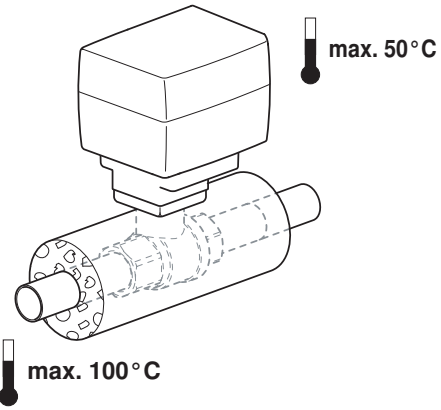
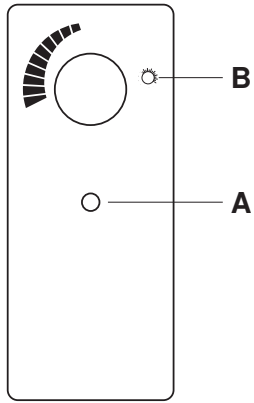

ARF24-SR-S

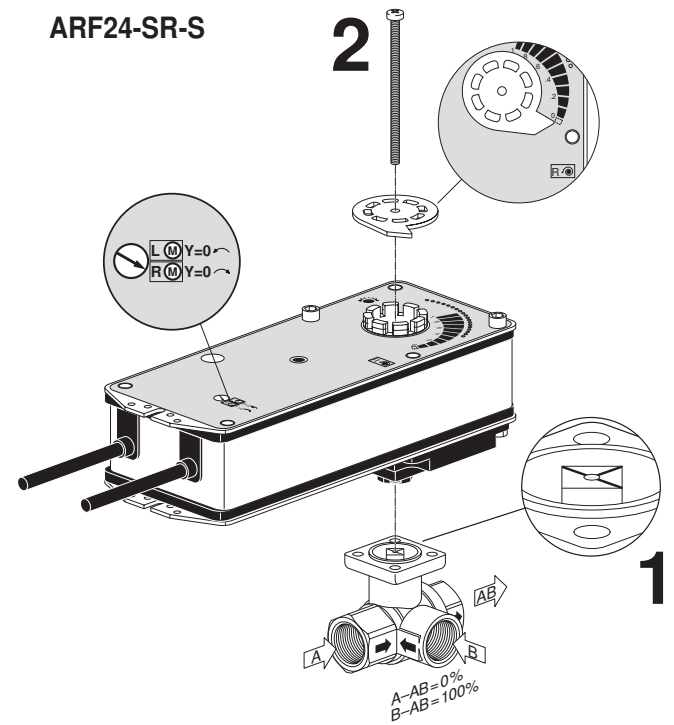

ARF24-SR-S

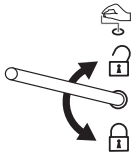

ARF24-SR-S-0

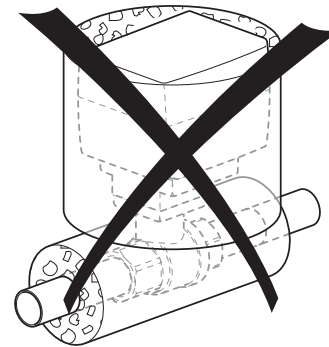
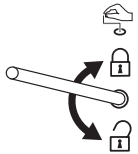

ARF24-SR-S-0

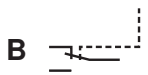
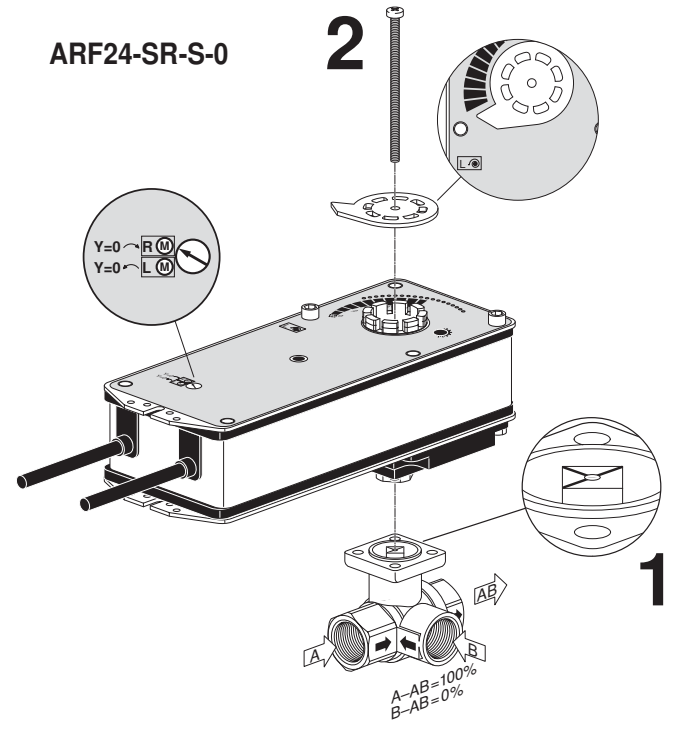

ARF24-SR-S

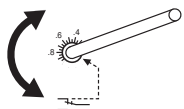

ARF24-SR-S-0

